

FIG #1 PLACE BASE LAYER ON FLAT LEVEL SURFACE. USE 1X3X4' STRAPPING/FURRING STRIPS FOR STICKERS.

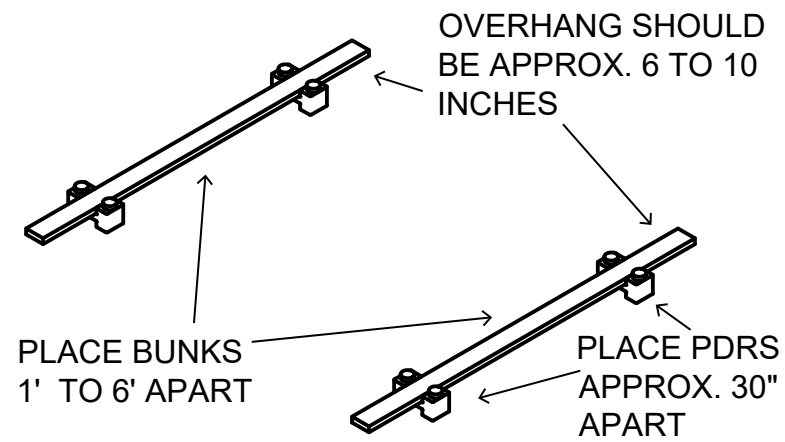
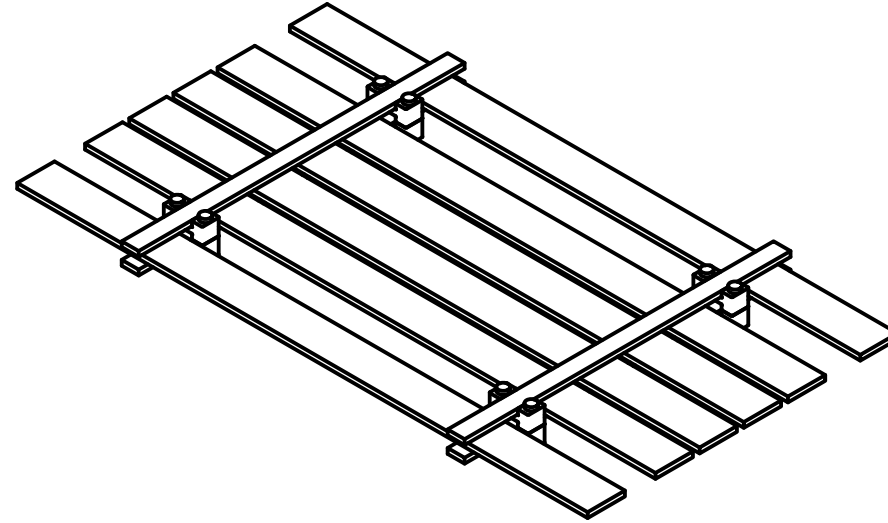

FIG #4 STACK 2ND SET OF PDRS AND 1X4X4' STRAPPING ON EXISTING BUNKS



CONTINUE STACKING AND LOADING FILLING CENTER THEN OVERHANG. UNLOAD IN REVERSE, REMOVE MATERIAL FROM OVERHANG FIRST THEN CENTER.

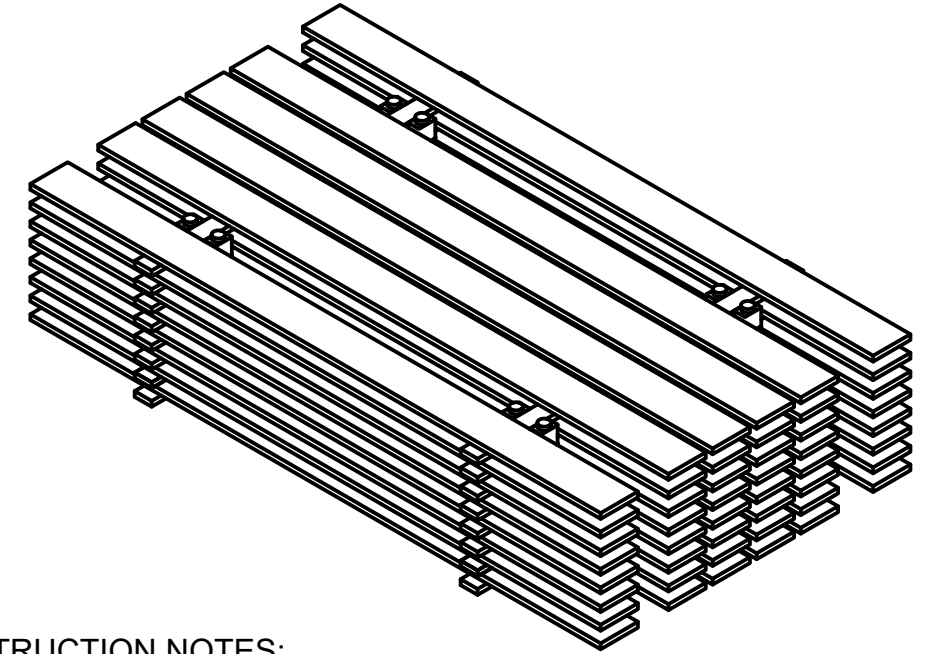

FIG #2 FILL CENTER WITH MATERIAL

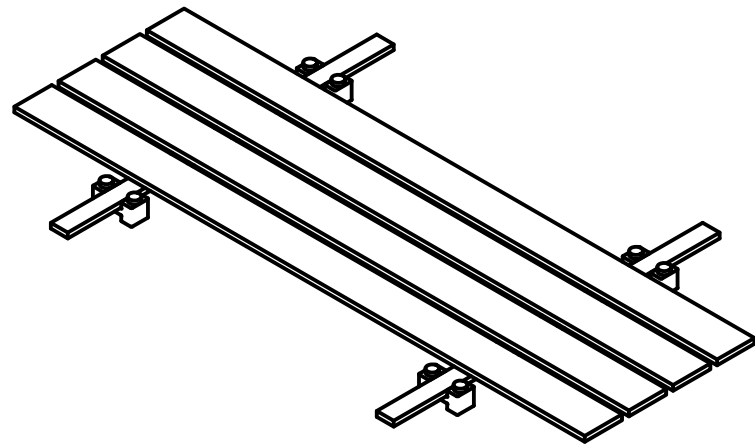
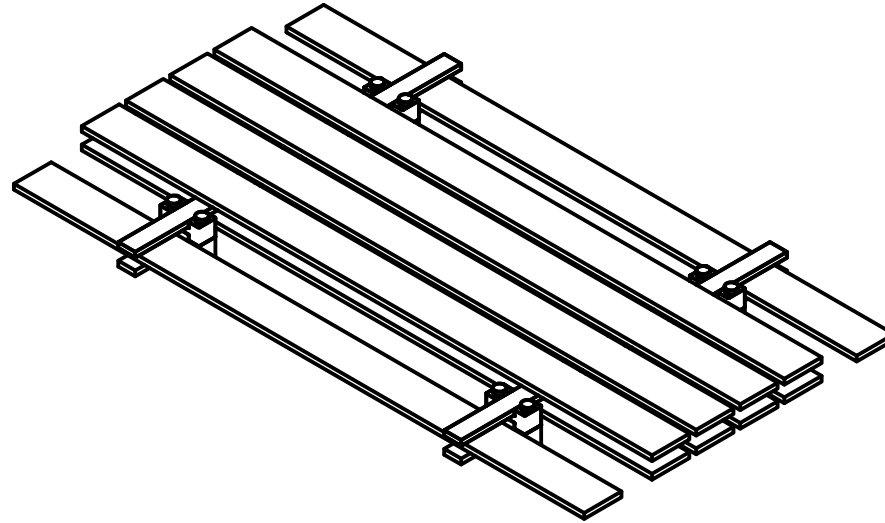

FIG #5 FILL CENTER WITH MATERIAL



INSTRUCTION NOTES:

- 1X3X4' STRAPPING/ FURRING STRIPS (SOLD SEPARATELY) WILL BE NEEDED FOR STICKERS BETWEEN LAYERS
- CENTER STRAPPING/FURRING STRIPS BETWEEN TWO PDRS APPROX. 30" APART WITH 6 TO 10 INCHES OF OVERHANG
- LOCATION OF THE PDR'S AND SEPARATION DISTANCE OF THE BUNKS VARIES DEPENDING ON LENGTH AND TYPE OF MATERIAL TO BE STACKED.
- SUGGESTED DISTANCE BETWEEN BUNKS;
 - 8' MATERIAL CENTER BUNKS 5' APART
 - 12' MATERIAL CENTER BUNKS 6' APART
 - 16' MATERIAL USE 3 SETS OF BUNKS, ONE IN CENTER AND TWO 6' AWAY ON SIDES.
- THE SECOND OR THIRD SET OF BUNKS SHOULD BE IN THE SAME CONFIGURATION AND IN LINE WITH THE FIRST
- IF PVC BOARDS OR SIMILAR FLEXIBLE MATERIAL ARE BEING STACKED, MORE BUNKS MIGHT BE NECESSARY.
- PLACE MATERIAL BEING PROCESSED PERPENDICULAR TO STRAPPING, FILLING THE CENTER FIRST THEN THE OVERHANGS.
- ONCE FIRST LAYER IS FILLED, PLACE 2ND SET OF PDRS ON THE FIRST WITH ANOTHER PIECE OF 1X3X4' STRAPPING IN THE SAME POSITION AS THE ONE BELOW. CONTINUE WITH SAME PROCEDURE FOR EACH LAYER
- UN LOAD IN REVERSE, REMOVE MATERIAL FROM THE OVERHANGS THEN THE CENTER.
- MAXIMUM HEIGHT IS 3' WITHOUT STABILIZING ACCESSORY.
- SYSTEM DESIGNED TO ACCOMODATE UP TO 5/4" MATERIAL, IF THICKER MATERIAL IS TO BE PROCESSED, TWO PDRS WILL BE NEEDED

FIG #3 FILL OVERHANG WITH MATERIAL

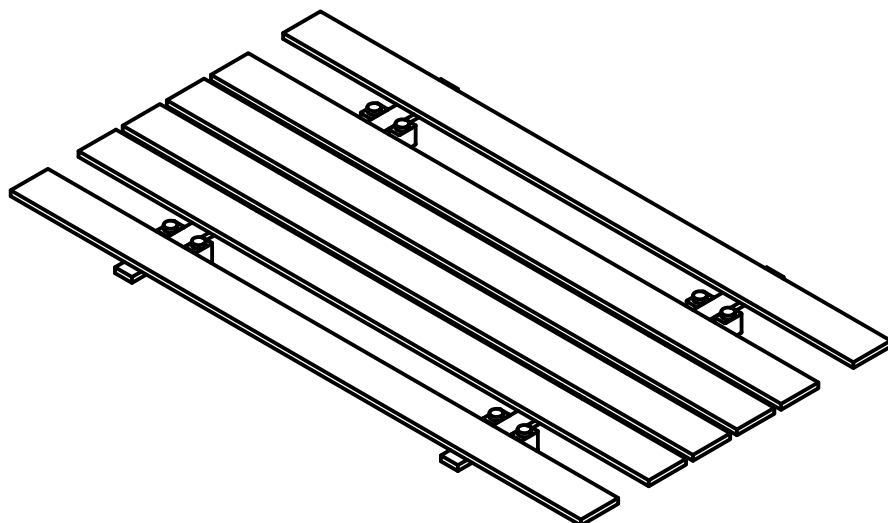

FIG #6 FILL OVERHANG WITH MATERIAL

